

man shorter
 century bird sandals
 saw paws straw
 dear series
 awful four
 lunchroom
 strawberries
 wind
Spelling
 Week of July 10
 honor
 rectangular very
 sir
 zoo time
 clear shop
 tomorrow claw seal

My Name: _____

Your Words

Pick 1 to do:

- page 1
- pages 2-3

Spelling Break

Pick 1 to do:

- page 10
- page 11

Spelling Workout

Pick 4 to do:

- page 4
- page 5
- page 6
- page 7
- page 8
- page 9

AW Words

Do this:

- page 12

Name: _____

Picture Dictionary

Draw a picture of 11 of your words. Write the word.



EXAMPLE. laughed _____

1. _____

2. _____

3. _____

4. _____

5. _____

Name: _____

edHelper

6. _____

7. _____

8. _____

9. _____

10. _____

11. _____

Name: _____

Week of July 10
Second Grade

awful k a o f u h a w f u l z w h t l f o l f

tomorrow v l i o w t o m o r r o w w o r o t o j

strawberries r s e d s t r a w b e r r i e s r b e r

paws p h p w a s z w v a p a w s p s o a t a

wind g d d d d a s t w i n f d w i w i n d i

sir n u j r b l o r s i r r i s a z h s i r

saw q x o a w s i w w c b s a w s a h a a g

bird j b i r d e i c r y p o b i r d n g a b

man w p a m m a n e m a n c t x a m h f b l

seal b t s e a l e n a i f s e i l s m s a c

zoo f z o o j l n z e o z o i h o z x o k o

clear e c l a r u p l h c l e a r b a r c t c

time i h e j t p t i o m e t i x t i m e w m

shop s h o p p s m i s h e p g e o s l n u t

claw x e b c l a w n l c m s k l a l u d o l

shorter e t c h o r t e r y o s h o r t e r r s

dear d g d s e d e a r f d e a r e a d r d r

four r f o u t r u s o b o f w r a f o u r t

very d v v e r y i w e e y s u f v e r r y l

straw e s a t s g s t r r a w s t r a w y t a

sandals m a h j u l s a n d a l s s a n d l e s

honor o w h o u n o r o h h r j h o n o r a s

century g y c e n u r y k c e n t u r y t e z i

series s e r i e s q e s k v n s s e r e i s a

Name: _____

Use each word ONCE. Cross off each word after it is used.

paws • zoo • man • wind • rectangular • honor • sir • clear
dear • sandals • seal • tomorrow • saw • lunchroom

These words have
"ear" in them.

___ e _ a _ r _

These words have the long u sound like
in cube.

___ z _ _ _ _

These words have "an" in them.

___ a _ n _

Fit the rest of the words into these shapes.

			s
--	--	--	---

		n	o	r
--	--	---	---	---

--	--	--

--	--	--

--	--	--	--

--	--	--	--	--	--	--	--

--	--	--	--

Name: _____

Which way does each word go? Write the word.

<p>1. → STILL ← SHOP ↓ STOOLS</p> <table border="1" style="width: 100%; border-collapse: collapse; text-align: center;"> <tr> <td style="width: 20px; height: 20px;"></td> <td style="width: 20px; height: 20px;"></td> <td style="width: 20px; height: 20px;"></td> <td style="width: 20px; height: 20px;">1 S</td> <td style="width: 20px; height: 20px;">T</td> <td style="width: 20px; height: 20px;">I</td> <td style="width: 20px; height: 20px;">L</td> <td style="width: 20px; height: 20px;">L</td> </tr> <tr><td style="background-color: #cccccc;">/</td><td style="background-color: #cccccc;">/</td><td style="background-color: #cccccc;">/</td><td></td><td style="background-color: #cccccc;">/</td><td style="background-color: #cccccc;">/</td><td style="background-color: #cccccc;">/</td><td style="background-color: #cccccc;">/</td></tr> <tr><td style="background-color: #cccccc;">/</td><td style="background-color: #cccccc;">/</td><td style="background-color: #cccccc;">/</td><td></td><td style="background-color: #cccccc;">/</td><td style="background-color: #cccccc;">/</td><td style="background-color: #cccccc;">/</td><td style="background-color: #cccccc;">/</td></tr> <tr><td style="background-color: #cccccc;">/</td><td style="background-color: #cccccc;">/</td><td style="background-color: #cccccc;">/</td><td></td><td style="background-color: #cccccc;">/</td><td style="background-color: #cccccc;">/</td><td style="background-color: #cccccc;">/</td><td style="background-color: #cccccc;">/</td></tr> <tr><td style="background-color: #cccccc;">/</td><td style="background-color: #cccccc;">/</td><td style="background-color: #cccccc;">/</td><td></td><td style="background-color: #cccccc;">/</td><td style="background-color: #cccccc;">/</td><td style="background-color: #cccccc;">/</td><td style="background-color: #cccccc;">/</td></tr> <tr><td style="background-color: #cccccc;">/</td><td style="background-color: #cccccc;">/</td><td style="background-color: #cccccc;">/</td><td></td><td style="background-color: #cccccc;">/</td><td style="background-color: #cccccc;">/</td><td style="background-color: #cccccc;">/</td><td style="background-color: #cccccc;">/</td></tr> <tr><td style="background-color: #cccccc;">/</td><td style="background-color: #cccccc;">/</td><td style="background-color: #cccccc;">/</td><td></td><td style="background-color: #cccccc;">/</td><td style="background-color: #cccccc;">/</td><td style="background-color: #cccccc;">/</td><td style="background-color: #cccccc;">/</td></tr> </table>				1 S	T	I	L	L	/	/	/		/	/	/	/	/	/	/		/	/	/	/	/	/	/		/	/	/	/	/	/	/		/	/	/	/	/	/	/		/	/	/	/	/	/	/		/	/	/	/	<p>1. ↓ TRAIL → TRY ← THINK</p> <p>2. ← PINS PLANET PARK</p> <table border="1" style="width: 100%; border-collapse: collapse; text-align: center;"> <tr> <td style="width: 20px; height: 20px;">/</td> <td style="width: 20px; height: 20px;">K</td> <td style="width: 20px; height: 20px;">N</td> <td style="width: 20px; height: 20px;">I</td> <td style="width: 20px; height: 20px;">H</td> <td style="width: 20px; height: 20px;">1 T</td> <td style="width: 20px; height: 20px;"></td> <td style="width: 20px; height: 20px;"></td> </tr> <tr> <td></td> <td></td> <td></td> <td style="width: 20px; height: 20px;">2</td> <td></td> <td></td> <td></td> <td style="background-color: #cccccc;">/</td> </tr> <tr><td style="background-color: #cccccc;">/</td><td style="background-color: #cccccc;">/</td><td style="background-color: #cccccc;">/</td><td></td><td style="background-color: #cccccc;">/</td><td style="background-color: #cccccc;">/</td><td style="background-color: #cccccc;">/</td><td style="background-color: #cccccc;">/</td></tr> <tr><td style="background-color: #cccccc;">/</td><td style="background-color: #cccccc;">/</td><td style="background-color: #cccccc;">/</td><td></td><td style="background-color: #cccccc;">/</td><td style="background-color: #cccccc;">/</td><td style="background-color: #cccccc;">/</td><td style="background-color: #cccccc;">/</td></tr> <tr><td style="background-color: #cccccc;">/</td><td style="background-color: #cccccc;">/</td><td style="background-color: #cccccc;">/</td><td></td><td style="background-color: #cccccc;">/</td><td style="background-color: #cccccc;">/</td><td style="background-color: #cccccc;">/</td><td style="background-color: #cccccc;">/</td></tr> <tr><td style="background-color: #cccccc;">/</td><td style="background-color: #cccccc;">/</td><td style="background-color: #cccccc;">/</td><td></td><td style="background-color: #cccccc;">/</td><td style="background-color: #cccccc;">/</td><td style="background-color: #cccccc;">/</td><td style="background-color: #cccccc;">/</td></tr> <tr><td style="background-color: #cccccc;">/</td><td style="background-color: #cccccc;">/</td><td style="background-color: #cccccc;">/</td><td></td><td style="background-color: #cccccc;">/</td><td style="background-color: #cccccc;">/</td><td style="background-color: #cccccc;">/</td><td style="background-color: #cccccc;">/</td></tr> <tr><td style="background-color: #cccccc;">/</td><td style="background-color: #cccccc;">/</td><td style="background-color: #cccccc;">/</td><td></td><td style="background-color: #cccccc;">/</td><td style="background-color: #cccccc;">/</td><td style="background-color: #cccccc;">/</td><td style="background-color: #cccccc;">/</td></tr> </table>	/	K	N	I	H	1 T						2				/	/	/	/		/	/	/	/	/	/	/		/	/	/	/	/	/	/		/	/	/	/	/	/	/		/	/	/	/	/	/	/		/	/	/	/	/	/	/		/	/	/	/
			1 S	T	I	L	L																																																																																																																		
/	/	/		/	/	/	/																																																																																																																		
/	/	/		/	/	/	/																																																																																																																		
/	/	/		/	/	/	/																																																																																																																		
/	/	/		/	/	/	/																																																																																																																		
/	/	/		/	/	/	/																																																																																																																		
/	/	/		/	/	/	/																																																																																																																		
/	K	N	I	H	1 T																																																																																																																				
			2				/																																																																																																																		
/	/	/		/	/	/	/																																																																																																																		
/	/	/		/	/	/	/																																																																																																																		
/	/	/		/	/	/	/																																																																																																																		
/	/	/		/	/	/	/																																																																																																																		
/	/	/		/	/	/	/																																																																																																																		
/	/	/		/	/	/	/																																																																																																																		

<p>Circle the second letter.</p> <p>T L S B H M K Z</p>	<p>20 + 56 = _____</p>	<table style="margin-left: auto; margin-right: auto;"> <tr><td style="text-align: right;">82</td></tr> <tr><td style="text-align: right;">- 79</td></tr> <tr><td style="text-align: right;">-----</td></tr> </table>	82	- 79	-----
82					
- 79					

<p>Count by 5s.</p> <p><u>8</u> , <u>13</u> , <u>18</u> , _____ , _____ , _____ , _____ , _____ , _____</p> <p>Draw ONE continuous line that touches every box ONCE. Count by 5s. Find the box with the number 8. Move up, down, right, or left. Keep counting until you reach 83. Do not move into a spot with a ghost.</p> <table border="1" style="width: 100%; border-collapse: collapse; text-align: center;"> <tr> <td style="width: 20px; height: 20px;"></td> <td style="width: 20px; height: 20px;"></td> <td style="width: 20px; height: 20px;">43</td> <td style="width: 20px; height: 20px;"></td> <td style="width: 20px; height: 20px;"> </td> <td style="width: 20px; height: 20px;"></td> <td style="width: 20px; height: 20px;"></td> </tr> <tr> <td style="width: 20px; height: 20px;"></td> <td style="width: 20px; height: 20px;">83</td> <td style="width: 20px; height: 20px;">- - - 78</td> <td style="width: 20px; height: 20px;"> </td> <td style="width: 20px; height: 20px;"> </td> <td style="width: 20px; height: 20px;"></td> <td style="width: 20px; height: 20px;"></td> </tr> <tr> <td style="width: 20px; height: 20px;">- - - -</td> <td style="width: 20px; height: 20px;"></td> <td style="width: 20px; height: 20px;"></td> <td style="width: 20px; height: 20px;">18</td> <td style="width: 20px; height: 20px;">- - - 13</td> <td style="width: 20px; height: 20px;">- - 8</td> <td style="width: 20px; height: 20px;"></td> </tr> </table>			43						83	- - - 78					- - - -			18	- - - 13	- - 8		<table style="margin-left: auto; margin-right: auto;"> <tr><td style="text-align: right;">82</td></tr> <tr><td style="text-align: right;">- 49</td></tr> <tr><td style="text-align: right;">-----</td></tr> </table>	82	- 49	-----
		43																							
	83	- - - 78																							
- - - -			18	- - - 13	- - 8																				
82																									
- 49																									

Name: _____

Week of July 10
Second Grade

Write these spelling words in ABC order:

clear • shop • rectangular • four • straw • paws

- | | |
|----------|----------|
| 1. _____ | 4. _____ |
| 2. _____ | 5. _____ |
| 3. _____ | 6. _____ |

Unscramble the letters to spell a word.

- | | |
|--------------------|----------------|
| irs _____ | ozo _____ |
| iesserartrbw _____ | owrotrom _____ |
| gltreuacnar _____ | spho _____ |
| roonh _____ | rufo _____ |
| urcnohlom _____ | ualwf _____ |
| ecnytur _____ | ryve _____ |
| wdin _____ | anm _____ |
| daer _____ | trwas _____ |
| irbd _____ | cwal _____ |
| ehosrrt _____ | was _____ |

Name: _____

Fill in the missing letters. Write a or o.

r____ll

h____ve

p____t

cr____wn

pers____n

gr____ndfather

Write the hidden word. Start at one letter and then move either left or right. Continue in same direction.

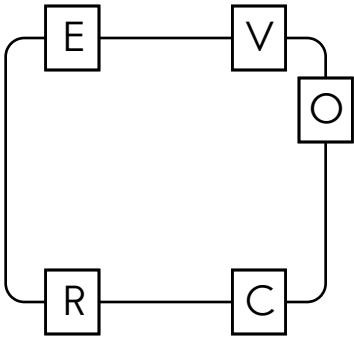

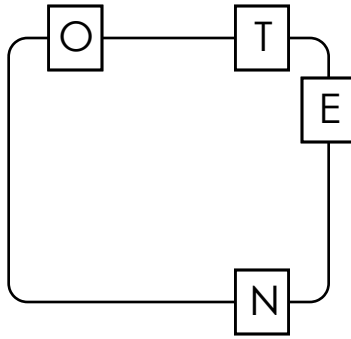

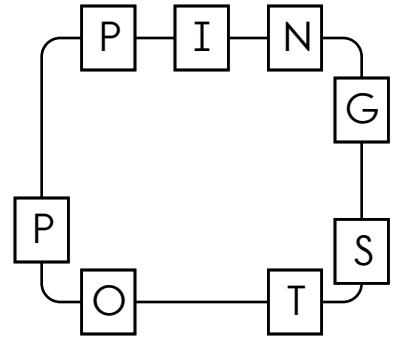

Fill in the blanks with these numbers:

6, 2

3 8

3 5

+ 3

9

Fill in the blanks with these numbers:

0, 2

1

2

+ 6 7

9 9

If October 11 is on a Thursday, then what day of the week will October 14 fall on?

5
6
+ 1

ten more than 362

0 ____ 0

< = >

5 + 2 + 9

15 16 24

5:00 a.m. to 1:00 p.m.

1 hour 3 hours
 6 hours 8 hours

Name: _____

Finish each sentence using a word from the box.

best brown came many

We made too _____ programs for our play.

The black dog _____ over for dinner.

They did their _____ .

Our _____ cat is small.

$$\begin{array}{r} 15 \\ + 33 \\ \hline \end{array}$$



Rewrite the sentence correctly.

she gave me a little blew goat

$$\begin{array}{r} 89 \\ - 77 \\ \hline \end{array}$$

d a f p l e a s e m
m y s e l f w w l d
e i d h d w h a t s
t c i y e o w h y p
h e d p l a y m c q
e a l o l d o p h d
y h r o e l t r y p

$$\begin{array}{r} 25 \\ + 87 \\ \hline \end{array}$$

$$\begin{array}{r} 86 \\ - 15 \\ \hline \end{array}$$

$$\begin{array}{r} 58 \\ - 25 \\ \hline \end{array}$$

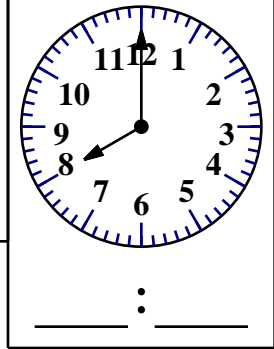

Word Bank

the try play
myself what why
please old did

Read the word.
Clap your hand for each syllable.
How many syllables?



magic

1 2 3 4 5

It is your turn. Write X to make your move.

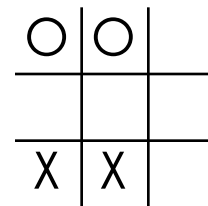

Name: _____

AW makes /aw/ sound

E R T C F D R A W S W R W W D
 G L A B A E S A R C R W P A A
 A N A S W G A D R Z S A R A C
 U W G T N J W P W W P A W S L
 W R D T T A S F N R N C W A A
 R S T R A W B E R R I E S S W
 I L L P W C A W S L D A W N S
 B W R R T A A A S A J A W C S
 W A W R R A P R S T R A W S T
 A R S C C R A W L I N G S W R

DAWN • CAW • FAWN • SAWS
 PAWS • STRAW • STRAWBERRIES
 DRAWS • CLAWS • CRAWLING
 JAW

Help! Some of the AW words from this page and the previous page are written like they sound. Can you figure out the real spelling of these words? Good luck.

fawn fawn _____

krawlihNG _____

straw _____

pawz _____

klawz _____

jaw _____

dawn _____

sawz _____

drawz _____

strawbEHrēz _____

ō kōz → cause

oo choo → chew

ā kāk → cake

ē fēt → feet

ī īs → ice

ō bōt → boat

ū kūt → cute

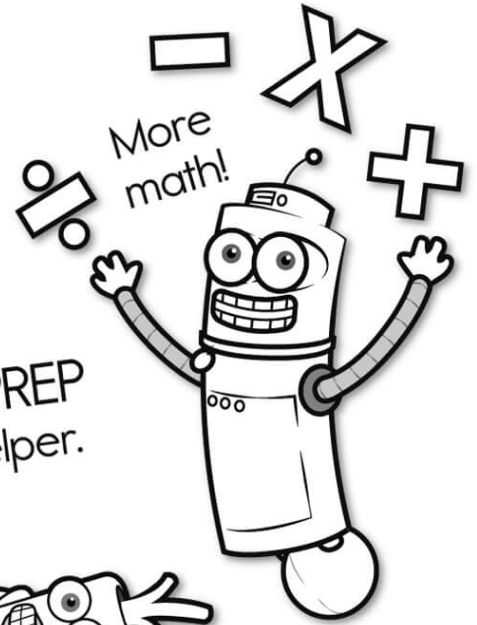
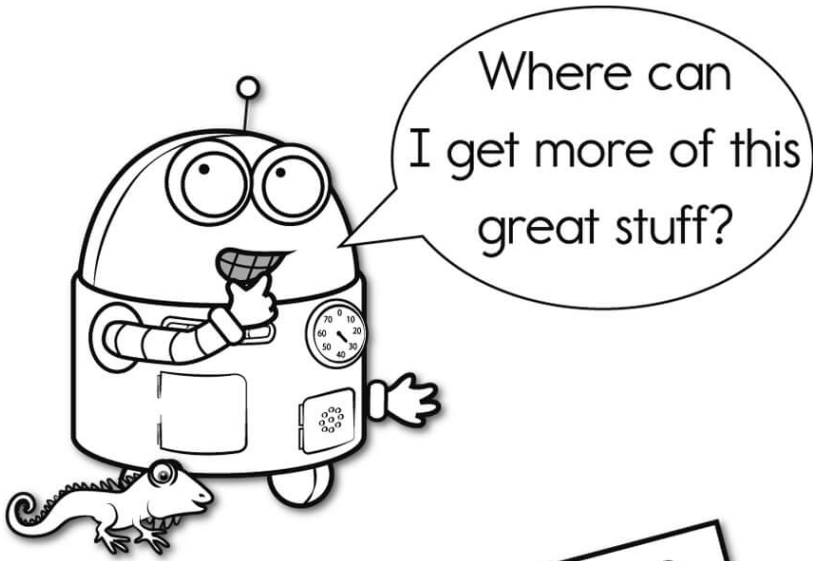

It's NO PREP at edHelper.

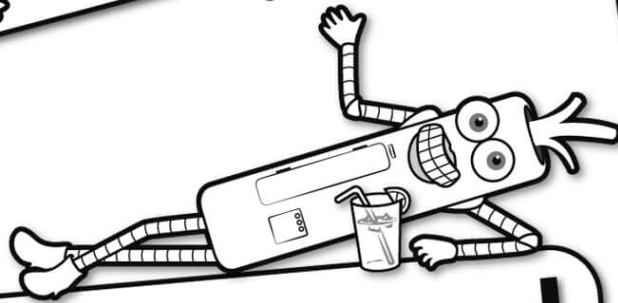

edHelper.com!

More history!

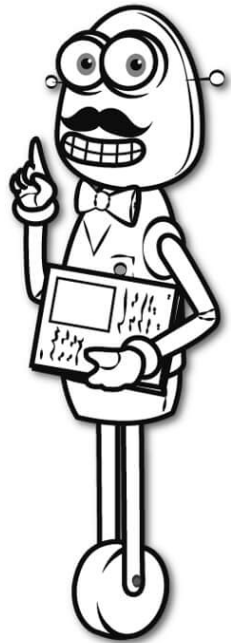

only \$19.99 per year

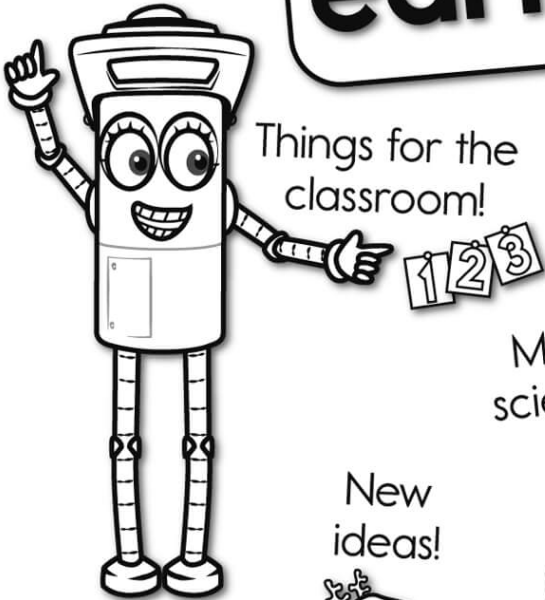

Things for the classroom!



New ideas!



More science!

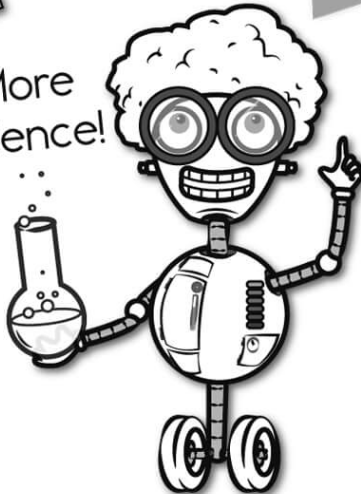

More puzzles!

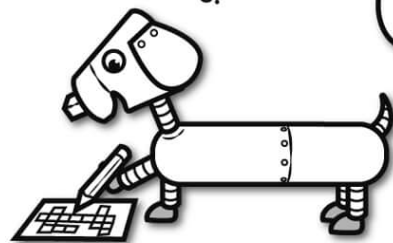

Take The Boring Out Of Homework!

Easy to
print!

edHelper

Weekly K-6 "Take It Home" Books

Kids want choices
for homework.
"Take It Home" books
have fun graphics and
challenging puzzles and
problems for older kids.

"Dr. Programmer"
challenges kids..

Homework
will never be
the same!

edHelper.com

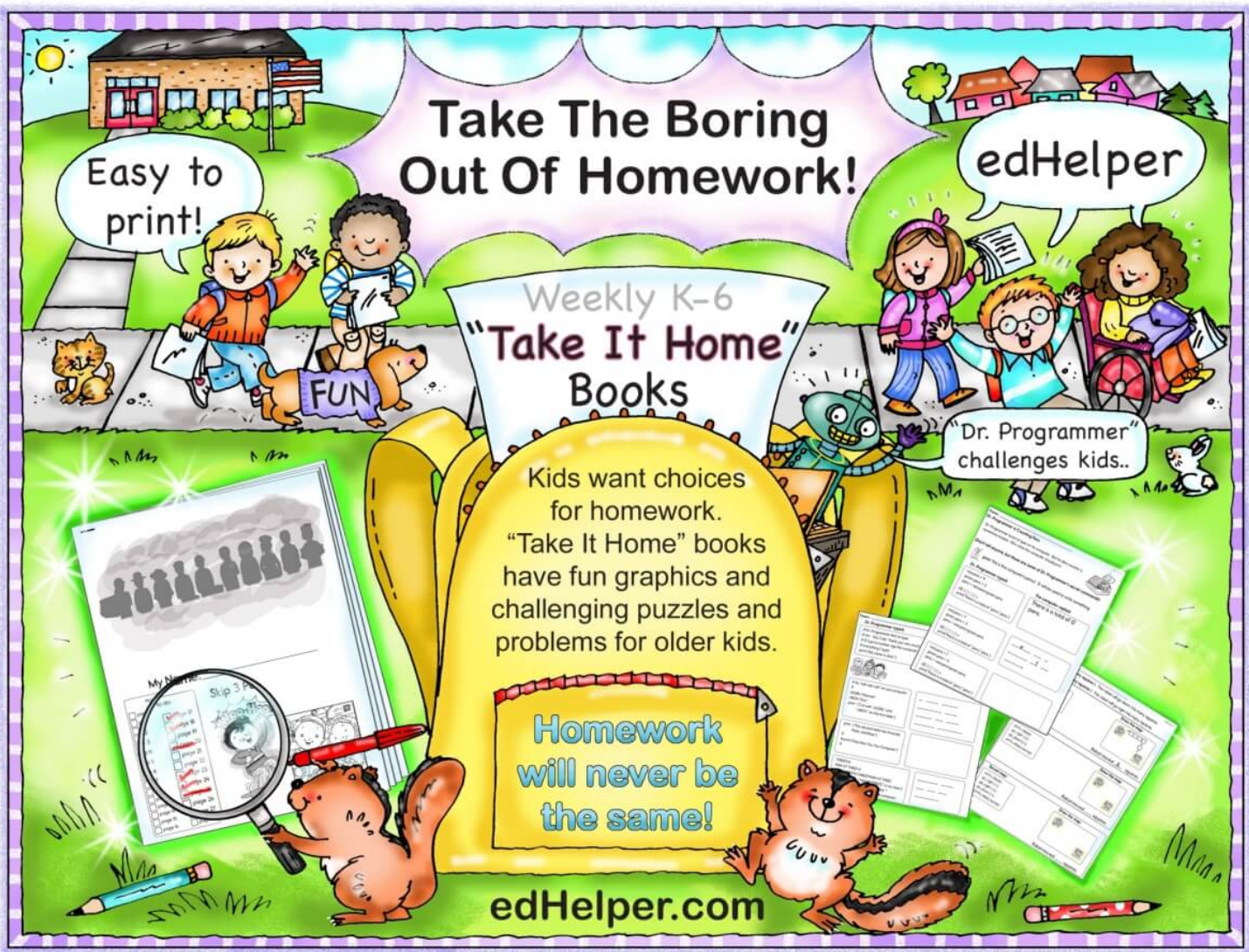

Thank you for using...



FreeEducationalResources.com